

GU-24 Series Lampholders

Provide New Alternatives for High-Efficacy Lighting in Residential and Commercial Applications



New lampholder design available in a choice of three mounting configurations:
Top: Bracket Mount (Cat. No. 26730)
Center: Panel Mount (Cat. No. 26740)
Bottom: Collar Mount (Cat. No. 26735)

Single, Universal Configuration Helps Manufacturers Comply With Key Energy Efficiency Standards

Leviton's new GU-24 Series bi-pin twist-lock lampholders address the pressing need for high-efficiency compact fluorescent replacement lamps that are now available in many consumer outlets. By creating a single, universal configuration, they provide a simple solution that can accommodate integrated-ballast compact fluorescent lamps in multiple wattages for both residential and commercial applications. And, most importantly, the GU-24 base lamps can be used in luminaires intended to comply with a host of recognized energy efficiency standards and regulatory mandates, such as ENERGY STAR and California Title 24.

Great Flexibility Allows Assembly And Cost Savings

The Leviton GU-24 fluorescent series allows manufacturers to expand their lines of screwshell-base incandescent luminaires to include compact fluorescent versions without costly retooling or modification. A choice of three different mounting configurations is offered. They are designed to match common medium-base screwshell lampholder mounting styles – bracket mount, collar mount and panel mount – as well as provide additional flexibility while saving cost and assembly time. They are ideal for a wide range of product applications including residential and commercial lighting fixtures, portable luminaires and decorative wall sconces.

Note: ENERGY STAR is a joint program of the U.S. Environmental Protection Agency and the U.S. Department of Energy. It helps consumers save money and protect the environment through energy efficient products and practices.

The Energy Efficiency Standards for Residential and Nonresidential Buildings (referred to as Title 24) were established in 1978 in response to a legislative mandate to reduce California's energy consumption. The standards are updated periodically to allow consideration and possible incorporation of new energy efficiency technologies and methods.

Features and Benefits:

- Designed for integrated-ballast compact fluorescent lamps with GU-24 base
- Accommodates most standard mounting configurations – panel, collar and bracket – for medium-base screwshell lampholders
- Accommodates standard wattages of GU-24 size lamps
- Helps satisfy ENERGY STAR and California Title 24 energy efficiency standards

Applications:

- Residential and commercial lighting fixtures
- Portable luminaires
- Decorative residential fixtures such as wall sconces, table lamps, and ceiling fixtures, etc.

Agency Standards:

UL Listed: cULus (File E5833)

Performance Specifications:

- Rated 250V, 120W
- Thermoplastic body material is PC; UL flammability rating is 94V-2

Ordering Information

Cat. No	Description	Mounting Information
26730	Bracket Mount GU-24 Base Lampholder	1/8-27 IPS Thread Bracket with Inside Extrusion
26735	Collar Mount GU-24 Base Lampholder	1/8-27 IPS Thread Collar with Set Screw
26740	Panel Mount GU-24 Base Lampholder	Eyelets Accept Nos. 4 & 5 Mounting Screws

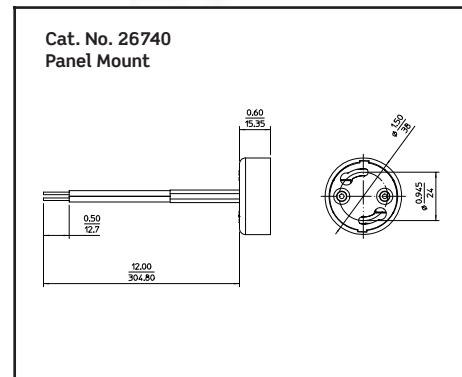
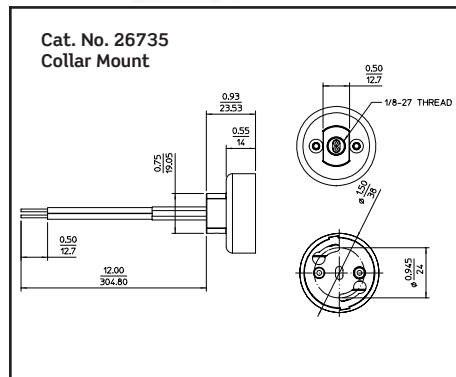
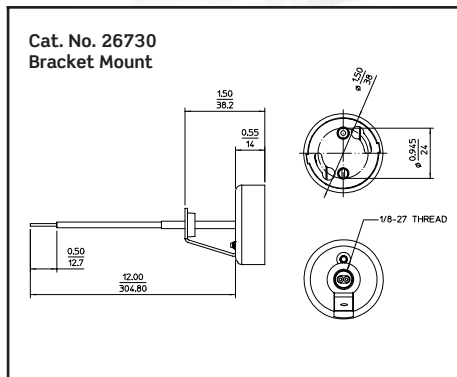

Note: Mounting Eyelets .840" center to center

Leviton Manufacturing Co., Inc.

59-25 Little Neck Parkway, Little Neck, NY 11362-2591
 Telephone: 1-800-323-8920 • FAX: 1-800-832-9538 • Tech Line (8:30AM-7:30PM E.S.T. Monday-Friday): 1-800-824-3005

Leviton Manufacturing of Canada, Ltd.

165 Hymus Boulevard, Pointe Claire, Quebec H9R 1E9
 Telephone: 1-800-469-7890 • FAX: 1-800-563-1853

Visit our Website at: www.leviton.com

